

**OPTIMA. Can a quality lift ever  
have been so cost-effectively  
designed?**

**OTIS**

Optima™





OPTIMA

RESIDENTIAL

OFFICES

SOCIAL HOUSING

PUBLIC BUILDINGS





CAR DESIGNS  
**3**

CAPACITY  
**4-26 passengers**

CAR WALL FINISHES  
**14**

**To suit differing market requirements, versatility is paramount. The OPTIMA™ concept has been conceived with 3 car designs and 14 car finishes.**

**QUALITY DRIVEN, COST-EFFECTIVELY DESIGNED.**

The OPTIMA car perfectly illustrates the notion that elegance can be achieved through simplicity - provided it's based on an inspired idea.

In the OPTIMA design's case, the idea is embodied by the car operating panel actually illuminating the car. Besides bathing the car in a soft diffused light, the panel also acts as a focal point for passengers.

The design of the COP is of course critical. With a curved faceplate, it is both simple and handsome. Chicklets with solid stainless steel target buttons add a touch of luxury as well as providing increased reliability.

Important to the refined appearance are the car panels themselves. In three finishes for different market needs, they are pleasing to the eye and easy to maintain. In fact it is the balance between the aesthetic and the practical that defines the OPTIMA car.



SKINPLATE



LAMINATE



STAINLESS STEEL







## 6 SKINPLATE FINISHES

At once tough and decorative, the skinplate wall panels consist of an eggshell textured PVC finish on a galvanised steel sheet. Designed to be practical, their pastel colours also create a bright ambience in the car.

The sense of spaciousness is enhanced by the white ceiling (curved or flat) and this is complemented by the white skinplate car operating panel. Optionally, the COP can be in brushed stainless steel.

Car facade and car doors are in white skinplate or brushed stainless steel.

Flooring is available in a variety of rubber designs or artificial stone.



### CAR PANELS

#### Skinplate

- ① Zircon Blue
- ② Sky Blue
- ③ Sand
- ④ Cream
- ⑤ Grey
- ⑥ Green



### FLOORING

As per samples shown below.

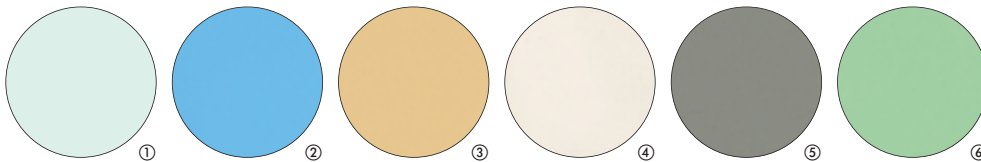

#### Rubber

- A Midnight blue
- B Charcoal
- C Coffee
- D Slip-resistant - black
- E Slip-resistant - grey

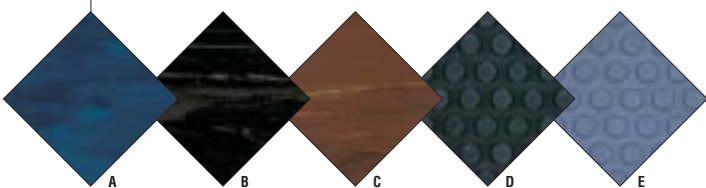

#### Artificial Stone

- F Black marble
- G Grey marble
- H Blue stone

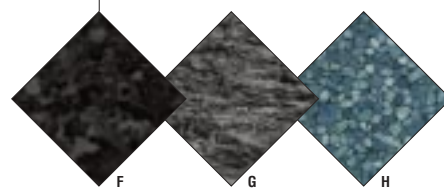

### FLOORING\*

\*CAR CAN BE SUPPLIED WITHOUT FLOORING IF PREFERRED.

## 6 LAMINATE FINISHES

Richly hued laminates with wood and marble finishes invest the OPTIMA car with a design flexibility that complements both traditional and contemporary interiors.

The curved ceiling is in white skinplate to match the finish of the car operating panel. A brushed stainless steel COP is optional.

Car facade and car doors are in white skinplate or brushed stainless steel.

Flooring is available in a variety of rubber designs or artificial stone.



### CAR PANELS

#### Laminate

- ① Lotus Noon
- ② Morello Cherry
- ③ American Maple
- ④ White Carrara
- ⑤ Grey Luxor
- ⑥ Crystal Loft



### FLOORING

As per samples shown below, to left.

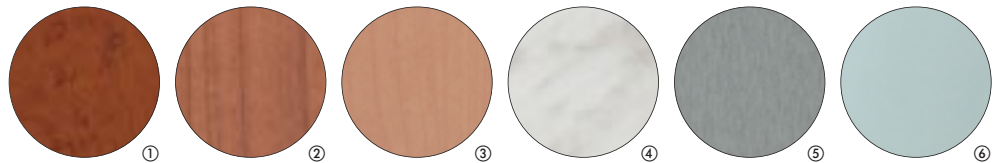

## 2 STAINLESS STEEL FINISHES

The robustly designed stainless steel car has a choice of two finishes: brushed or buffalo skin.

Emphasis has been placed on durability and all components are designed and tested to meet the highest standards of resistance to occasional or unintentional damage.

To complement the wall panels, the car operating panel has a stainless steel faceplate.

Car facade and car doors are in brushed or buffalo skin stainless steel.

Flooring is available in a variety of rubber designs or artificial stone.



### CAR PANELS

#### Stainless steel

- ① Brushed
- ② Buffalo skin



### FLOORING

As per samples shown at bottom, on facing page.

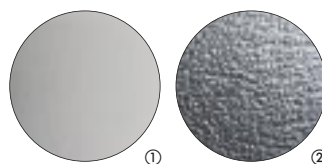

## CAR FITTINGS

Elegance is enhanced by quality car fittings. Hence panel trims are natural anodized, mirror chrome or satin chrome. So too are the kickplates.

The same design rigour has been brought to the handrails which offer a combination of contrasting finishes.

### HANDRAILS

Designed to comply with the relevant codes, the handrail consists of a bar and end cap. Finish combinations are shown below.

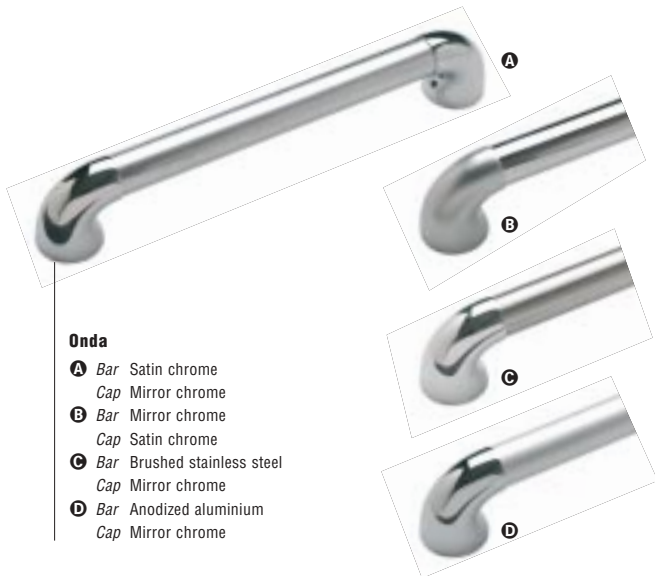

### MIRRORS

The bright, clear, non-tinted mirrors are in compliance with safety regulations to provide maximum passenger protection.

#### Typical arrangements:

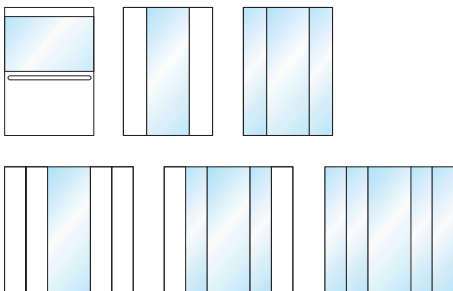

## SAFER ACCESS

The OPTIMA car is designed to fully comply with the European standard, EN81-70 that provides recommendations to facilitate general lift use and also use by the disabled.



### CAR DIMENSIONS

Minimum entrance widths for car sizes are:

- > **Type 1 (450 kg) - Car 1000 x 1250 mm**  
Accommodates 1 wheelchair user.
- > **Type 2 (630 kg) - Car 1100 x 1400 mm**  
Accommodates 1 wheelchair user and one passenger.
- > **Type 3 (1275 kg) - Car 2000 x 1400 mm**  
Accommodates 1 wheelchair user and several passengers. Wheelchair can be rotated.

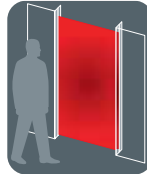

### ENTRANCE PROTECTION

To prevent passengers being struck by the doors, the OPTIMA design can be fitted with the LAMBDA™ 2. The system consists of a screen of infra-red beams which act as an invisible curtain across the door entrance, extending from 25 mm to 1800 mm above the sill.

### OTHER SAFETY FEATURES

- **Mirror**
  - > A mirror enables a wheelchair user to have a clear vision when reversing out of the lift.
- **Buttons**
  - > Red ring illumination and audible signal denote an activated floor button.
  - > Green ring identification for the lobby button protrudes by 5 mm.
- **Floor numbers**
  - > In relief, and with Braille characters, the floor numbers are 15 mm high.
- **Alarm pictograms**
  - > Alarm pictograms on the data plate, together with audible signals, indicate when the alarm button has been pressed and when voice communication has been established.
- **Car and hall direction indicators**
  - > Indicators incorporate 40mm direction arrows. An adjustable audio signal denotes arrival: one gong for upward direction, two gongs for downward.
- **Handrail**
  - > Handrail ends are turned into the wall for greater safety.
- **Audible signals**
  - > All audible signals are adjustable from 35 to 65 dBA.
- **Emergency lighting**
  - > An optional induction loop aids passengers with impaired hearing.

## CAR OPERATING PANEL

The originality of the car operating panel is that it illuminates the car. Curved in shape, it runs the full height of the car for maximum illumination.



### Liquid Crystal Display Screen (LCD)

Designed to be easily visible from all angles, the LCD houses the Car Position Indicator and the Car Direction Indicator

Bezel surround finished in satin chrome

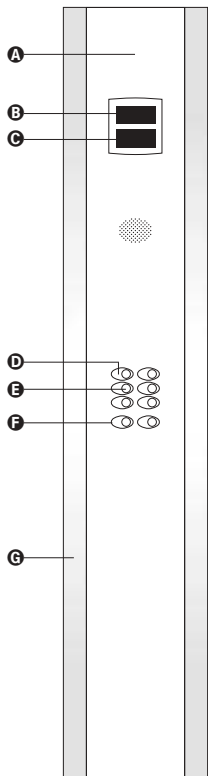

#### A Faceplate

> Curved in white skinplate or brushed stainless steel finish.

#### B Combined Car Position Indicator and Car Direction Indicator

#### C Data Plate

> Car capacity plus yellow and green pictograms showing when alarm call is made and voice communication is established.

#### D Chicklets

> Satin chrome finish with backlit numerals 15mm high.  
> Braille characters.

#### E Target buttons

> In solid stainless steel with mirror or brushed finish.  
> Red ring illumination.

#### F Ancillary buttons

> Door Open and Alarm buttons are positioned beneath the floor buttons. So too are optional keyswitches.

#### G Lighting

> Two fluorescent tubes emitting a soft diffused light around the car with translucent plastic diffuser.





## LANDING FIXTURES

Designed to harmonise with different styles of landing decoration, OPTIMA hall fixtures are integrated into a slim housing to minimise building interface and facilitate installation. In two finishes – mirror stainless steel and brushed stainless steel – they are engineered for reliability and durability.

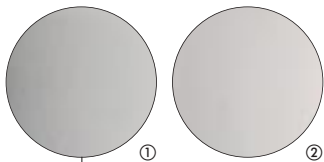

**Finishes for all the range (except Car Direction Lantern)**

- ① Brushed stainless steel
- ② Mirror stainless steel

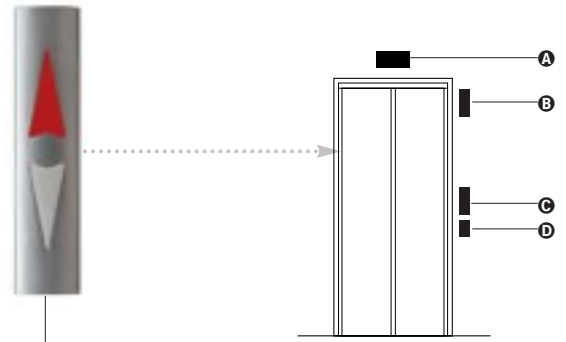

**Car Direction Lantern**

Located in the door jamb, the Car Direction Lantern is finished in satin chrome.



A Left

Right

**A Left**  
**Combined Hall Position Indicator and Signal Hall Lantern**

- > Sophisticated high resolution LCD (Liquid Crystal Display) technology.

Right  
**Signal Hall Lantern**

- > Positioned above the door entrance.
- > Long life LED (Light Emitting Diodes) component technology with red illuminating arrows.
- > Gong signal with different tones for 'up' and 'down' directions.



B

**B Left**  
**Combined Hall Position Indicator and Signal Hall Lantern**

- > Positioned on the upper side of door entrance.

Right  
**Signal Hall Lantern**

- > Long life component technology (LED) with red illuminating arrows.
- > Gong signal with different tones for 'up' and 'down' directions.



C

**C Left**  
**Hall Button Box**

- > Integrated Car Position Indicator and Signal Hall Lantern.

Centre and right  
**Hall Button Box**

- > Red ring illumination.

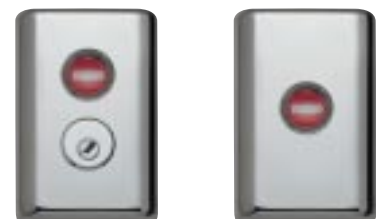

D

**D Option**  
**Keyswitches and Jewels**

- For special facilities.

[www.otis.com](http://www.otis.com)

Details of the product design are subject to change.